

Maszt o wietleniowy z opraw LED

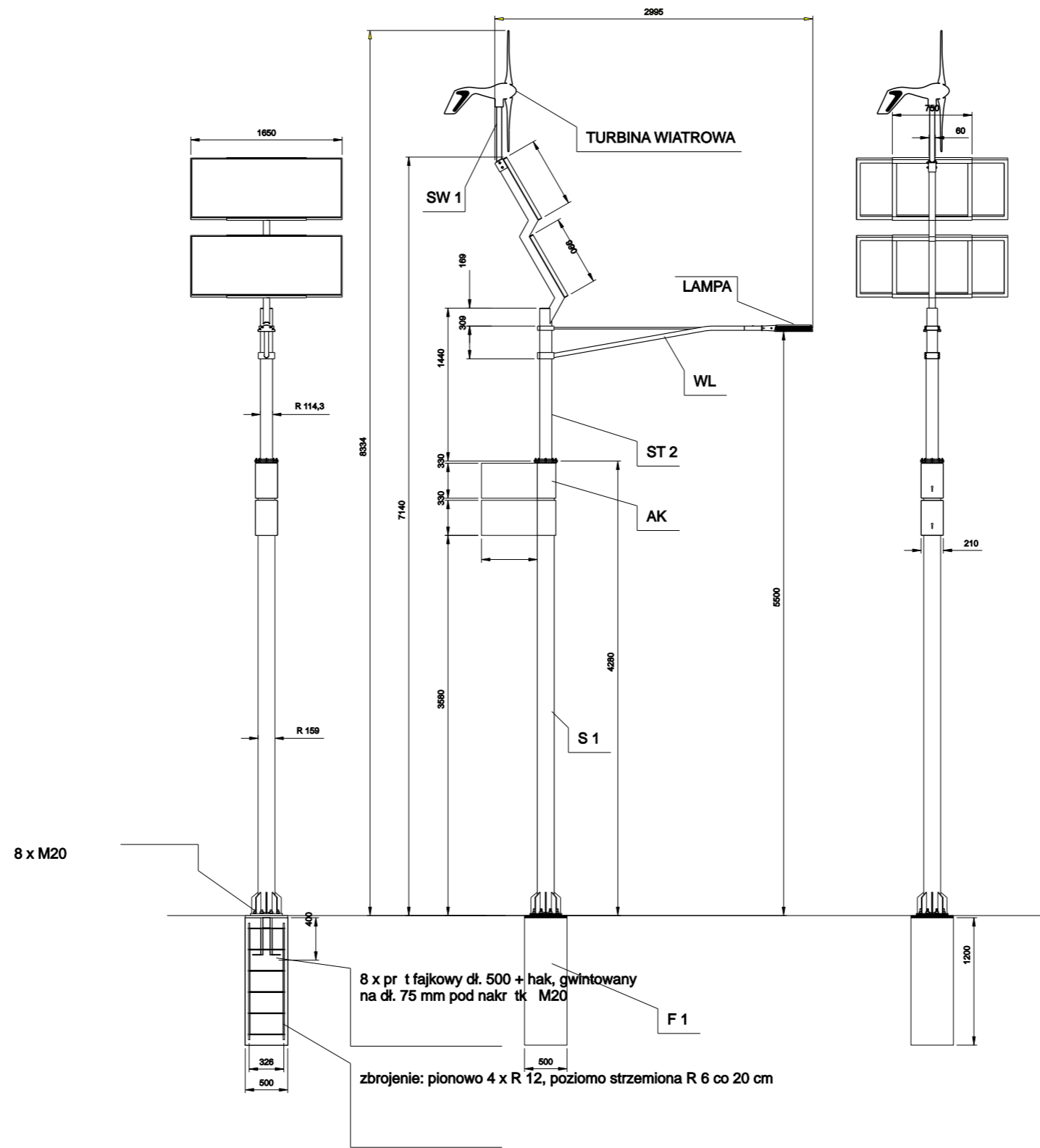

Fundament F2 pod maszt o wietleniowy

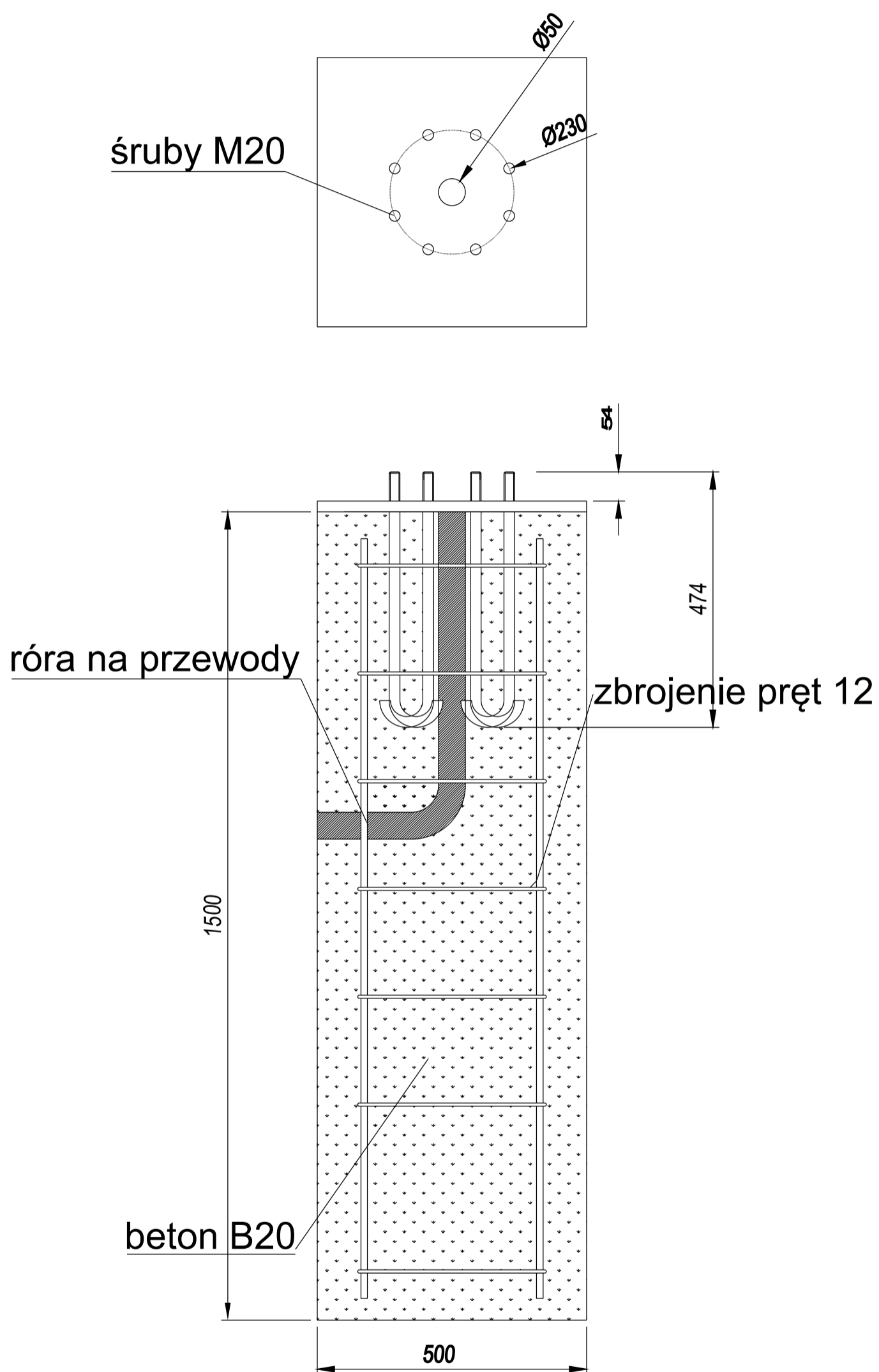

Schemat elektryczny

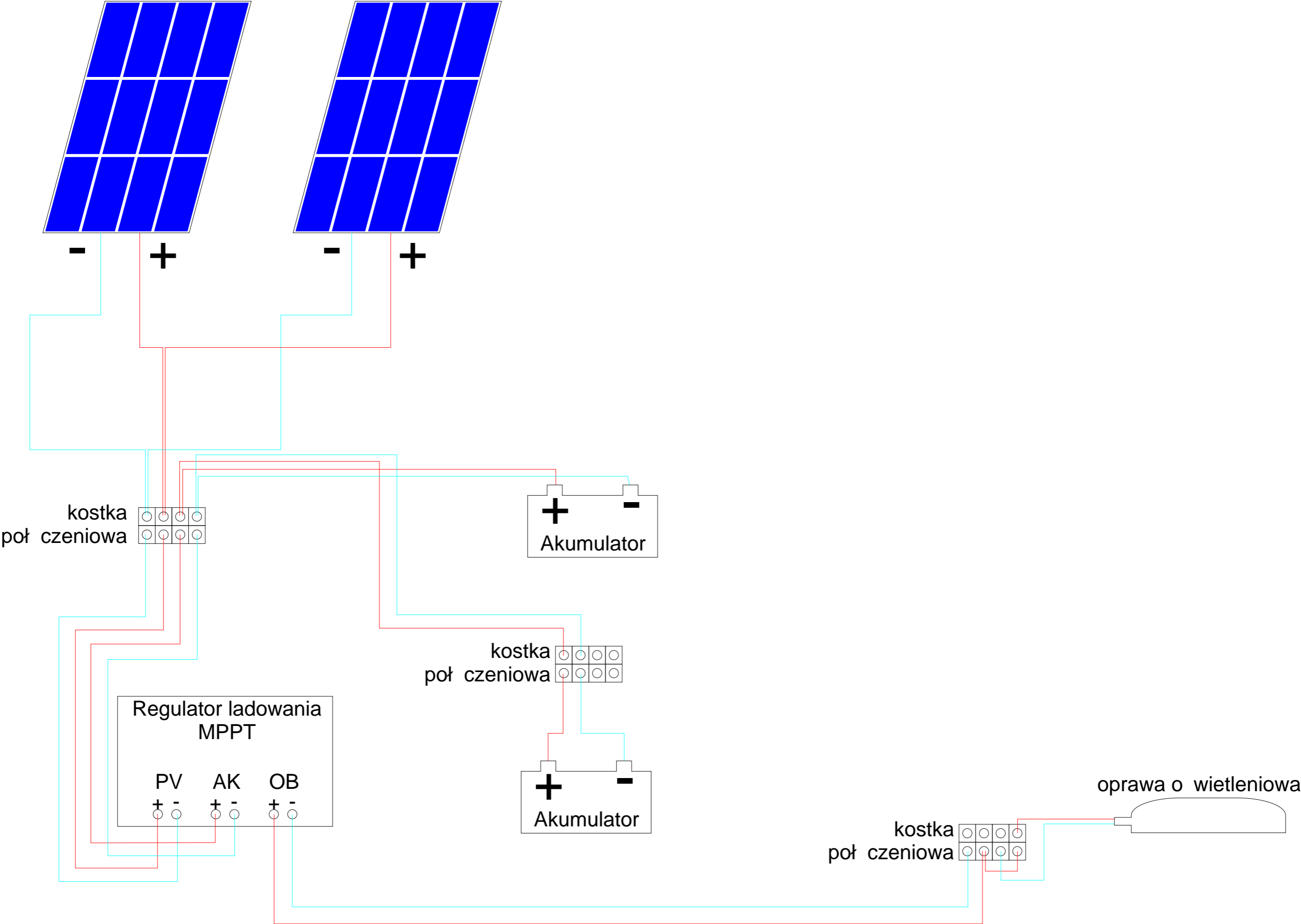

Kosz na 2 baterie słoneczne

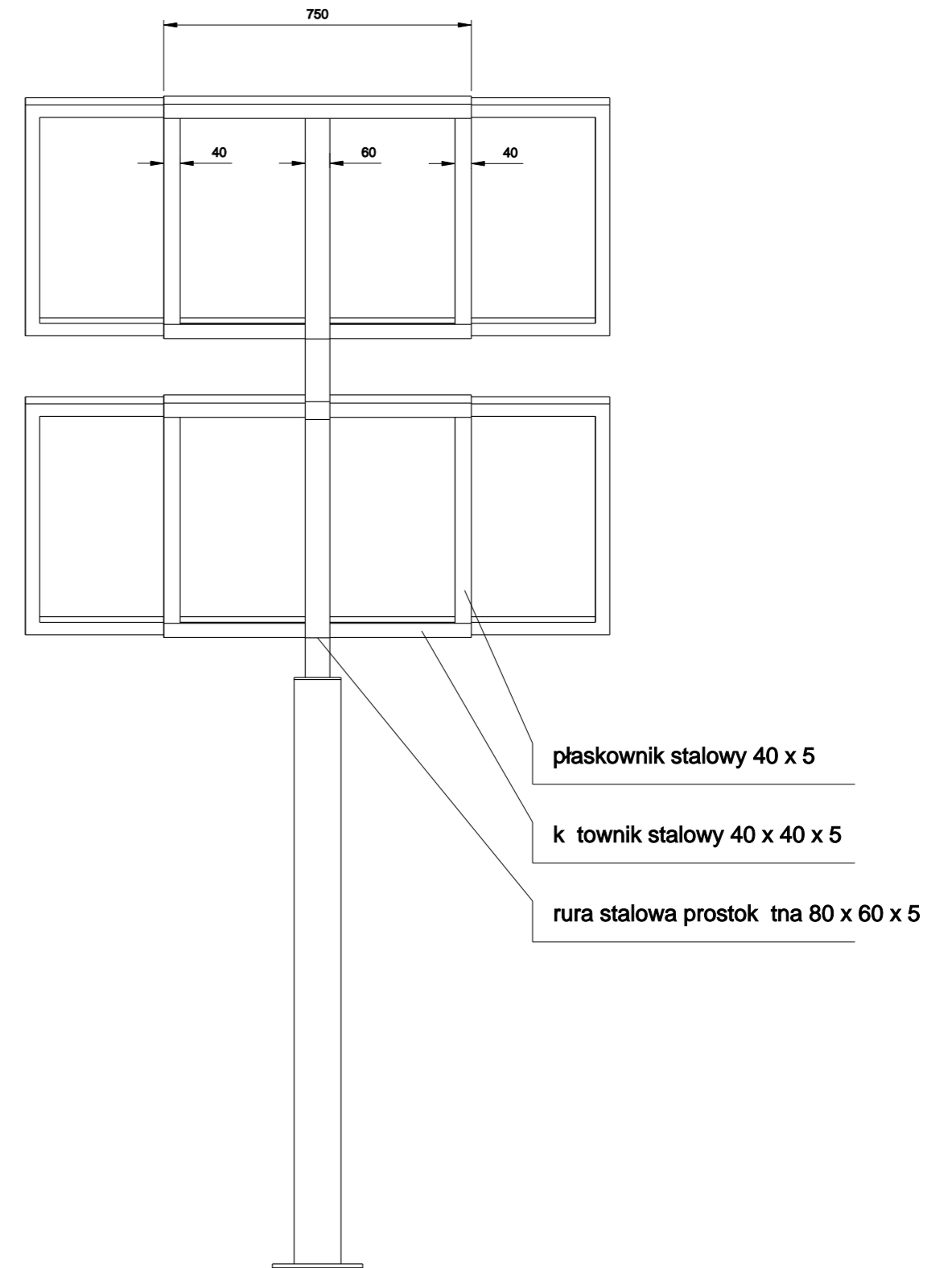
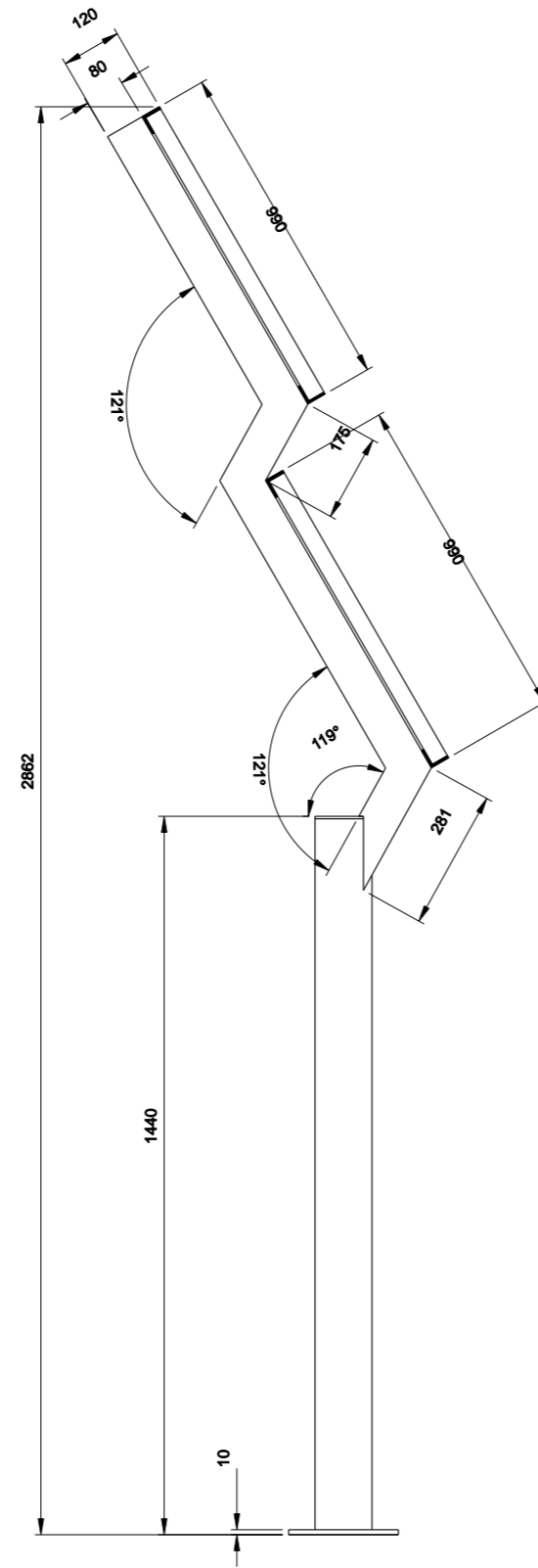
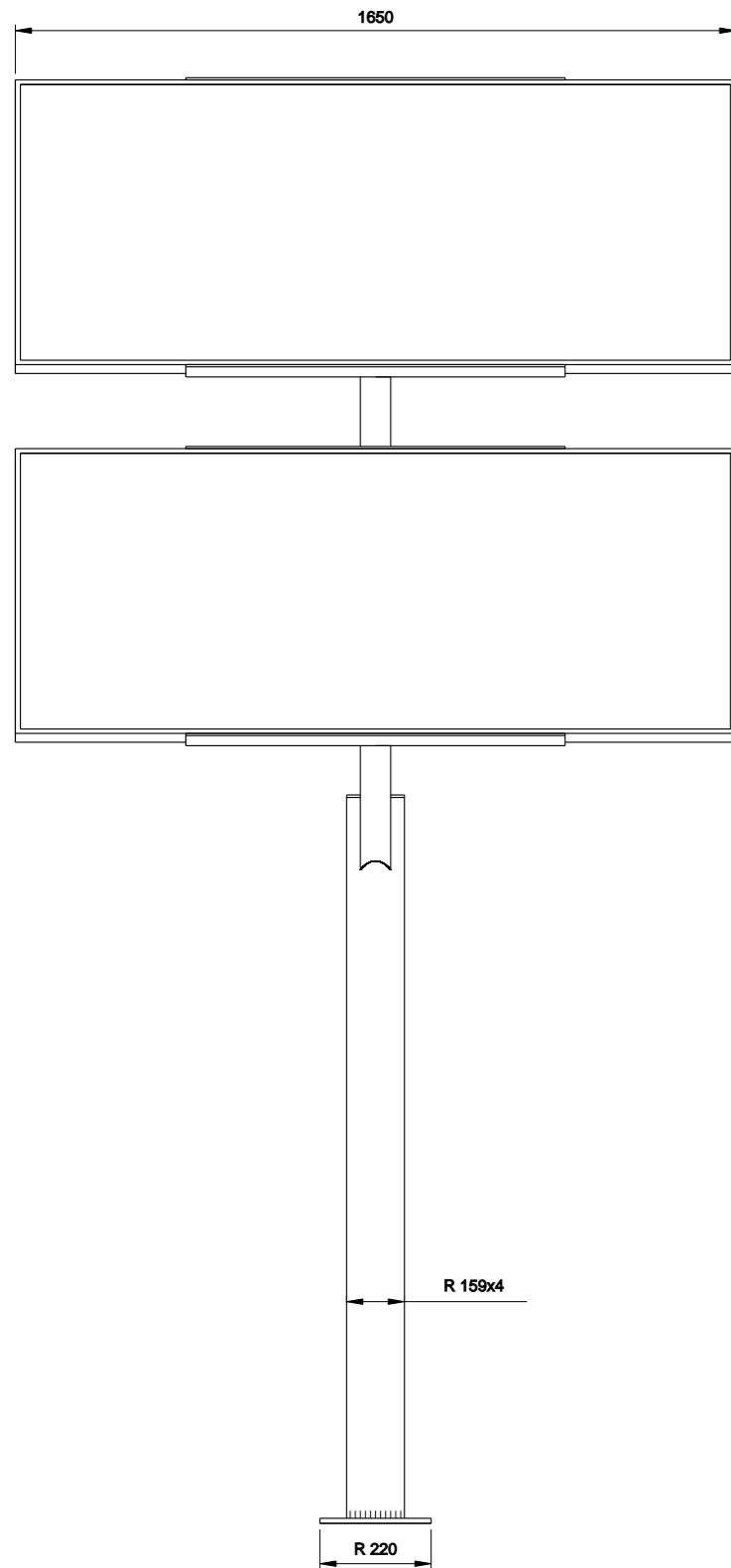

Skrzynki zabezpieczaj ce

